

خدمت رسانی به تولیدکنندگان ایرانی
SERVING IRANIAN MANUFACTURERS



100+

سال تجربه

Years of Experience



صباحی / برند مورد اعتماد صنعت

**Sabahi \ Your Trusted Brand
in The Industry**

1000+

مشتریان وفادار

Loyal Customers



مشتریان ما، کارخانجات ایرانی

**Our Customers are
Iranian Factories**

3

نسل متوالی

Generations Ongoin



اعتبار ما ، سرمایه ماست

Our Credibility is Our Fortune

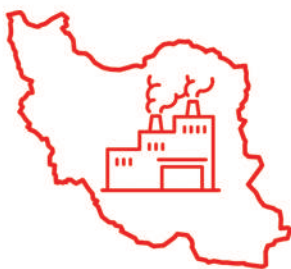

گروه صباچی با بیش از یک قرن سابقه، متشکل از شرکتهای فعال در بخشهای مختلف صنعتی، تجاری و تولیدی به فعالیت می‌پردازد که بنیان‌گذاری و ریاست گروه را آقای ناصر صباچی بر عهده دارند و هم‌اکنون به کمک نسل سوم خانواده در حال رشد و ترقی است. شرکتهای زیرمجموعه گروه با نام‌های بازرگانی صباچی و پودرهای میکرونیزه ایران بر پایه کسب‌وکار مستقیم و با استراتژی شفافیت در بازار داخلی و خارجی، به صورت مکمل و هم‌سو برای ارائه بهترین‌ها فعالیت می‌کنند. بازرگانی صباچی در شاخه‌های تأمین مواد اولیه دارویی، اقلام بسته‌بندی، تجهیزات و ماشین‌آلات و انتقال تکنولوژی در حال فعالیت است. همچنین شرکت پودرهای میکرونیزه ایران در صنعت پلیمر مشغول می‌باشد. ما با کسب اعتماد مستمر و پایدار که نتیجه آن داشتن زنجیره طولانی مدت تجاری با بیش از ۲۱۰۰ مشتری در اقصی نقاط کشور است، آماده خدمت‌رسانی به شما هستیم.

Sabahi Group is a multi-industry corporate group headquartered in Iran, Tehran. Sabahi is a family owned and operated organization that began its trade and marketing activities over a century ago. Mr. Nasser Sabahi, founder and chairman of the group, established Sabahi Enterprises as the first official company, under the family name, in year 1980. Now in its 5th decade of operations, Sabahi Enterprises has been supplying raw materials, packaging materials, equipment, machinery, and technology to Iranian manufacturers within various industries, markedly: the Pharmaceutical, Oils & Oleochemicals, Starch & Derivatives, Tire & Rubber, and Polymers & Plastics industries. Five years ensuing the establishment of the first member company, Micronized Powders Company of Iran was inaugurated as the manufacturing and second subsidiary of the group, in year 1985.



ستار صباحی / Sattar Sabahi



ناصر صباحی / Nasser Sabahi
بنیان‌گذار و ریاست گروه / Founder and chairman

پیام ریاست گروه

ما بارها نظاره‌گر پشیمانی مردمی بوده‌ایم که با خود می‌گویند: "اگر ۱۰ سال پیش بود، چنین و چنان می‌کردم" برای ما امروز آغاز ۱۰ سال آینده است؛ امروز با شهامت، بی‌پروا و شجاعانه عمل خواهیم کرد تا ۱۰ سال بعد با خود بگوییم "موفق شدیم" به جای آنکه بگوییم "بایستی چنین می‌کردیم".

با کمال افتخار کاتالوگ گروه صباحی را در معرض دید شما قرار می‌دهیم. این کاتالوگ علاوه بر معرفی لیستی از کالاها و خدمات با کیفیتی که ما به مشتریان خود ارائه می‌دهیم، شما را با کسب‌وکار، ارزش‌ها و استانداردهای کاری ما آشنا خواهد کرد. اینجانب ناصر صباحی در اواسط قرن بیستم میلادی، در یک خانواده بازرگان بزرگ شدم. پدرم مرا تشویق کرد تا کسب‌وکارم را به صورت حرفه‌ای دنبال کنم و یک تکنوکرات بشوم. من در فضایی بزرگ شدم که مرا کاملاً در تماس با بازرگانان در بازار ایران، چه بازار قدیم و چه بازار جدید قرار داد. من مدارک دانشگاهی متعددی در زمینه‌های کسب‌وکار، مهندسی، فلسفه و ریاضیات اخذ نموده‌ام.

در حالی که مشغول تحصیل در ایالات متحده بودم، هیچ‌گاه نگاه خود را از بازار ایران برنداشتم. پس از بازگشت به ایران در سال ۱۳۵۴، اولین شرکت خود را با نام شرکت بازرگانی صباحی در سال ۱۳۵۹ تأسیس نمودم. هدف من گسترش کسب‌وکار خانوادگی در حوزه خشکبار بود که پدرم در سال ۱۳۱۲ آن را بنا نهاده بود. حضور فعال من در بازار ایران باعث شد تا به خوبی از نیاز رو به رشد بازار کشورم به واردات فناوری از کشورهای خارجی آگاهی پیدا کنم.

این مسئله باعث چرخشی در کسب‌وکار حرفه‌ای من شد که با الهام بخشیدن به نسل‌های آینده در دستیابی کامل به ظرفیت‌های خود و اجرای راهکارهای خلاقانه برای رشد تجاری از یک صادرکننده به یک واردکننده و نماینده انحصاری تولیدکنندگان خارجی درجه یک تبدیل شدم.

Message from the Chairman

We build the future and we are wary that regret is fruitless. For us, today is the beginning of the next ten years; today we will be daring, we will be confident, we will be bold, so that in ten years' time we can wholeheartedly say to ourselves "we succeeded!"

I grew up in a family of merchants in mid-20th century Iran. My father encouraged me to pursue a professional degree and live as a technocrat. But, having been involved in our family business from childhood, surrounded by merchants of the old world and new world in Tehran's Grand Bazaar, I had attained deep connections to trading. In 1966, in pursuit of new life experiences, I left Iran for the United States. I spent more than a decade studying and working in the U.S. and received multiple graduate degrees in the distinct yet related fields of Business, Engineering, Philosophy, and Mathematics. Throughout my stay abroad, my heart and mind continued to be enthralled by the Bazaar. In 1975, I returned to Iran to begin trade, and by 1980 established Sabahi Enterprises Co. as an official business organization.

To expand my father's trade in export of dried fruits, which he had founded in 1913, was an initial goal; however soon, I recognized Iran's developing need for new technology that could only be compensated through foreign imports. My active presence in Iran's market had made me intuitive of my country's exigencies. Switching from exports to imports led to a pivoting point in my professional career. With great dedication and the help of my hard-working colleagues, I entered the imports business and soon after, received recognition as one of the most reputable and prominent companies in modern Iran.

Iran, residing on one of the largest global oil and gas reserves in the world, earns significant income through the export of these materials. Such riches have made our country one of the most important export destinations in the world. Iranian Industrial Revolution, beginning 1970 AD, was further endorsed by the many foreign investments in the country. The influx of international capital went hand in hand with an increase in the volume of imports. The economy's astonishing rapid growth thus needed to be supported with the import of further goods and services. Within this stream, Sabahi Group has been able to establish itself as a leading supplier of technology, machinery, and raw materials in a variety of industries in the country.

Nasser Sabahi

Chairman of Sabahi Group of Companies

Sabahi Group Logo

Conception of a Legacy



گروه صباحی همانند چرخ آسیاب، مولد تحرک و نیرو است.

Sabahi Group translates the potential of the market flow into performance that drives expansion and growth.

گروه صباحی (چرخ آسیاب) به همراه تیم صباحی (پیمانها) به تشخیص و بررسی نیازهای بازار (جریان آب) پرداخته و آنها را قابل اجرا و عملیاتی می‌سازد. جریان آب، نماد نیازهای بازار در ابعاد و اشکال متنوع می‌باشد.

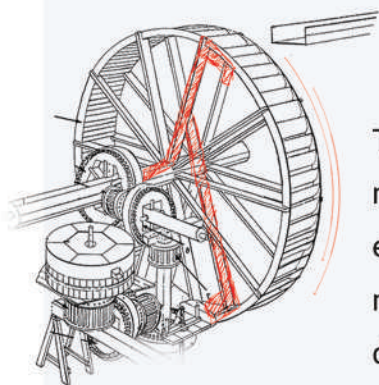

The force of running streams has been harnessed for centuries to produce mechanical power that makes efficient and effective work possible, leading to economic growth and human prosperity around the world. Parabolic to a water mill's system, in business, market demands are like the flow of water; market demands thus drive the turning of the wheel.

در نتیجه، صنعت (آسیاب) با شتاب و نیروی ایجاد شده توسط تیم صباحی، به صورت بهینه به حرکت در می‌آید تا توسعه، نوآوری و رشد را برای تولیدکنندگان ایرانی رقم بزند.

Sabahi team on a daily mission to meet the demands of the market are symbolized by the paddles of the structure. The wheel, also the emblem of Sabahi Group, is the foundation of the entire system, turning by the continuous efforts of the team. Thus, Sabahi Group, in essence, is a generator of operational power that paves the way for innovation, new developments, and ultimately prosperity of the market.





Sabahi Group of Companies



۱۳۵۹/1980

تاسیس شرکت بازارگانی صباحی

Sabahi Enterprises Co. is founded



۱۳۶۴/1985

تاسیس شرکت پودرهای میکرونیزه ایران

Micronized Powders Co. of Iran is Founded

پودرهای میکرونیزه ایران
Micronized Powders of IRAN



بازرگانی صباحی
Sabahi Enterprises

نماینده انحصاری تامین کنندگان خارجی / فروش مستقیم و مطمئن

Exclusive representative of reputable international suppliers /
making direct and reliable sales

SINCE 1980

از سال ۱۳۵۹

خدمات بازرگانی صباحی بازاریابی و فروش محصولات تامین کنندگان خارجی به
تولیدکنندگان ایرانی در صنایع مختلف است.

Sabahi Enterprises serves as the Iranian branch of prominent international
companies, marketing, promoting, and selling their products to local
manufacturers within various industries.



تایر و لاستیک
Tire & Rubber



پلیمر و پلاستیک
Polymers & Plastics



روغن، چربی و اولئوکمیکال
Oils, Fats, & Oleochemicals



علوم زیستی
Life Sciences

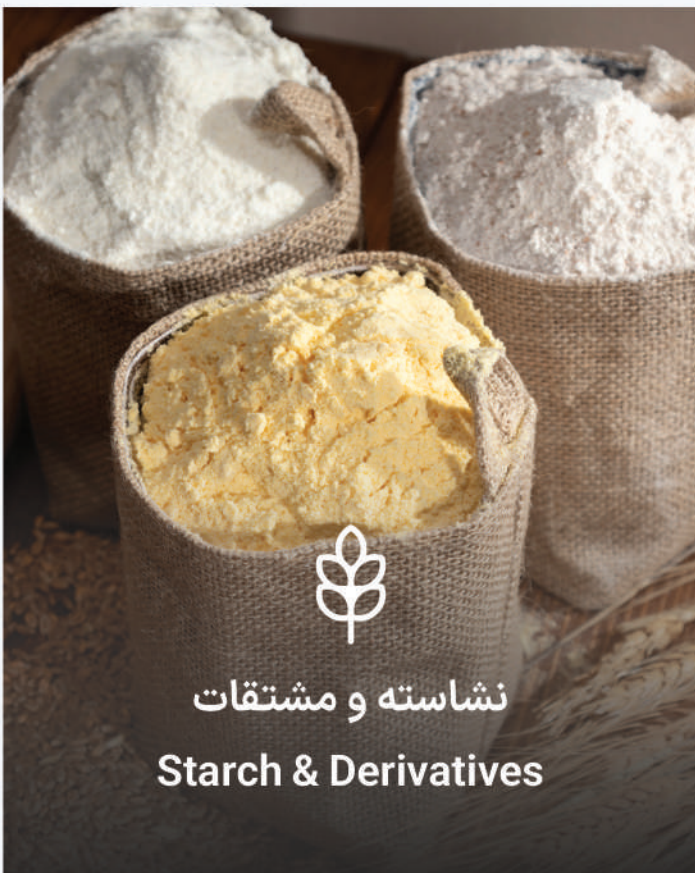

نشاسته و مشتقات
Starch & Derivatives

صنعت علوم زیستی

Life Sciences Industry

علوم زیستی یکی از پنج صنعت و از مهم‌ترین صنایع زیر مجموعه شرکت بازرگانی صباحی می‌باشد. صنعت علوم زیستی، شامل صنایع داروسازی، آرایشی-بهداشتی و تجهیزات پزشکی است.

The Life Sciences is one of five departments and a paramount sector under Sabahi Enterprises Co. The Life Sciences division appeals to manufacturers within the pharmaceuticals, medical devices, cosmeceuticals, and hygienics industries.



در صنعت علوم زیستی چه می‌کنیم؟

What do we do in our Life Sciences Department?

تامین زنجیره کامل

Supplying the entire chain:



ماشین‌آلات
Machinery



اقلام بسته‌بندی
Packaging

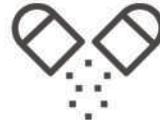

مواد اولیه
Raw Materials





Raw Materials Overseas and Domestic Sales

فروش

انواع مواد اولیه

به صورت ارزی و ریالی

Raw Material Categories 800+ Products

- / Active Pharmaceutical Ingredients (APIs)
- / Antibody Drug Conjugates (ADC)
- / Cosmeceutical Ingredients
- / Directly Compressible (DC) Granules
- / Enzymes
- / Excipients
- / Extracts
- / Flavors & Fragrances
- / Intermediates, Fine and Specialty Chemicals
- / Insulin APIs, all types
- / Peptides
- / Vitamins



Sabahi's Local Warehouse *(APIs and Excipients)*

- / 1,300 sqm. in area
- / GSP Approved
- / 1,200 metric tons of storage capacity
- / **Located in Tehran**, an hour away from Iran's pharmaceuticals hub
- / **Warehouse team**, especially trained for GDP handling of materials

Empty Capsules



Widest range of standard capsule sizes in any color you need.



Regular Gelatin Capsules

- / For best performance and reliability
- / Available in 15 sizes and more than 10,000 color shades
- / Immediate release
- / Proven machine-friendly design

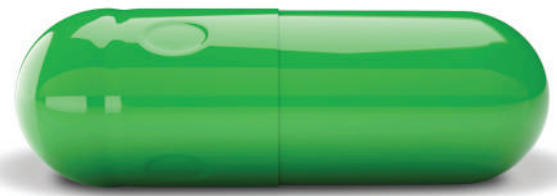

Regular HPMC Capsules

- / Made from natural plant-sourced cellulose
- / No animal origin materials used in manufacturing
- / Superior heat stability with no cross-linking
- / Low inherent moisture



Liquid and Combination Fill Capsules

- / Available in gelatin and HPMC variants
- / Ideal choice for filling liquids and combination fills
- / Secured band sealing after encapsulation of liquids
- / Easier way to accomplish brand differentiation



Customized Printing of Capsules

- / Provides effective protection against counterfeiting
- / Unique way to achieve effective brand differentiation
- / 360° solution enables full circular oriented printing
- / Attractive printing using up to 4 colors



Pharma Packaging Solutions

- / Blister Films
- / Blister Foils
- / Lidding Foils
- / Child Resistant Foils
- / Laminates

Films / Foils

Innovation

Offering unique & impactful solutions

Barrier strength properties

Barrier against moisture, light, gases etc.

Machinability of materials

Designed for high speed manufacturing

Compatibility with machinery

Compatible with all blister machines

Printability of complex designs

Flexo or rotogravure printing with great detail

Glass Packaging

A One-stop Shop ظروف شیشه‌ای

/ Iran Ministry of Health registered.

/ TYPE 1 Borosilicate glass, in colors amber and clear, in all sizes.

/ Four plants with 100% camera inspection and sensor measuring systems.



Sterile Solutions / Tubs, Trays, and Nests



Tubular Vials



Cartridges



Ampoules



Glass Pre-fillable Syringes (PFS) / Components can be provided by [West](#) [Aptar](#) [DATWYLER](#)

- / Disposable Pre-filled Injector Pens
- / Reusable Injector Pen
(In metal & plastic)
- / Pre-filled Syringes Auxiliary
Injector Device
- / Multifunctional Cosmetic Pens

Used for Products

- / Liraglutide
- / Semaglutide
- / Insulin Glargine
- / FSH
- / HGH
- / Insulin Aspart

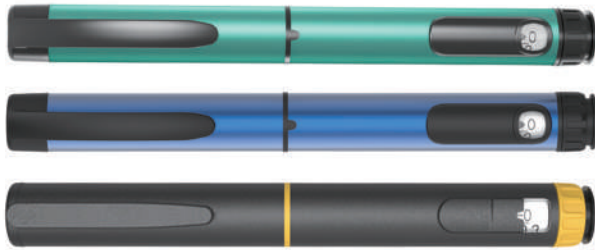

قلم‌های تزریقی



Disposable & Reusable Injector Pens

Material Handling Systems

Machinery / Process

ماشین آلات خطوط هازارد / ایزولاتور



Process Containment Technology

- / Flexible Containment System
- / Multi-purpose Isolation System
- / Sterility Test Isolators
- / Granulation Isolator

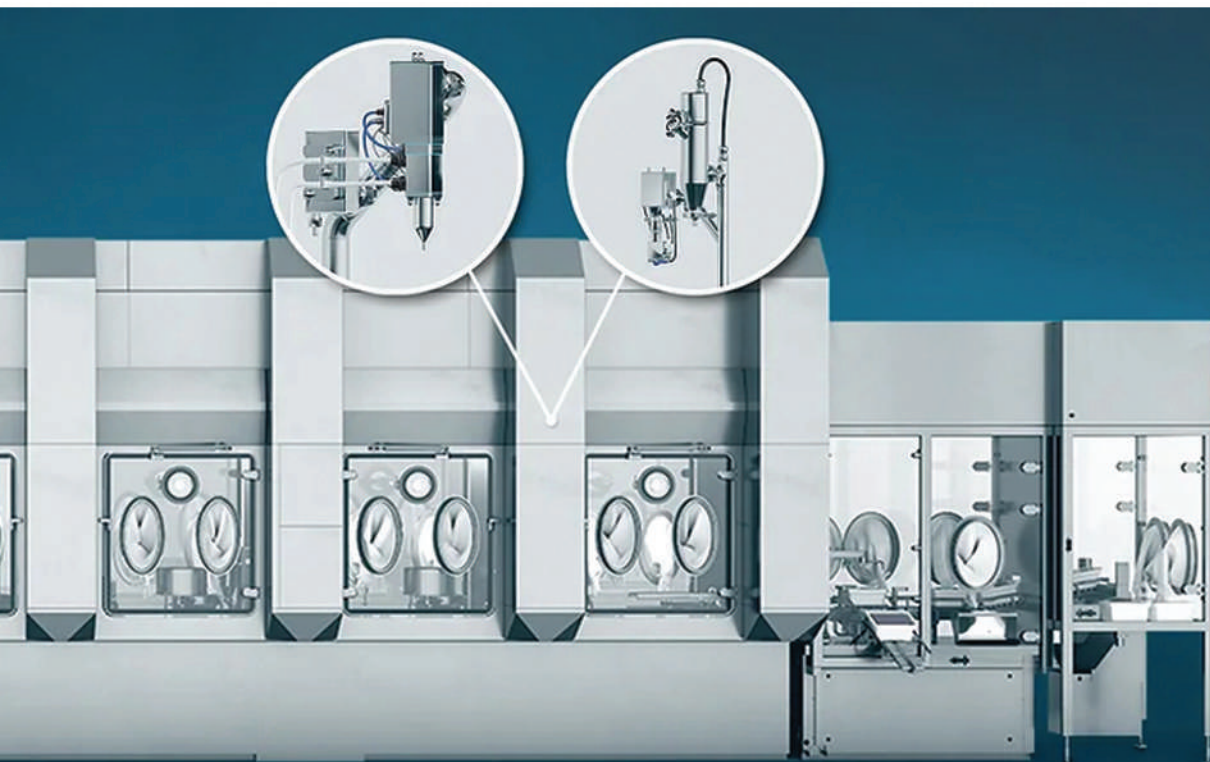



Delivering Customized Solutions for High Potent Drugs

- / End-to-end Project Deliverance
- / Dispensing of API to Final Packing
- / Cost-effective Project Solutions
- / In-house OEL Validation Team

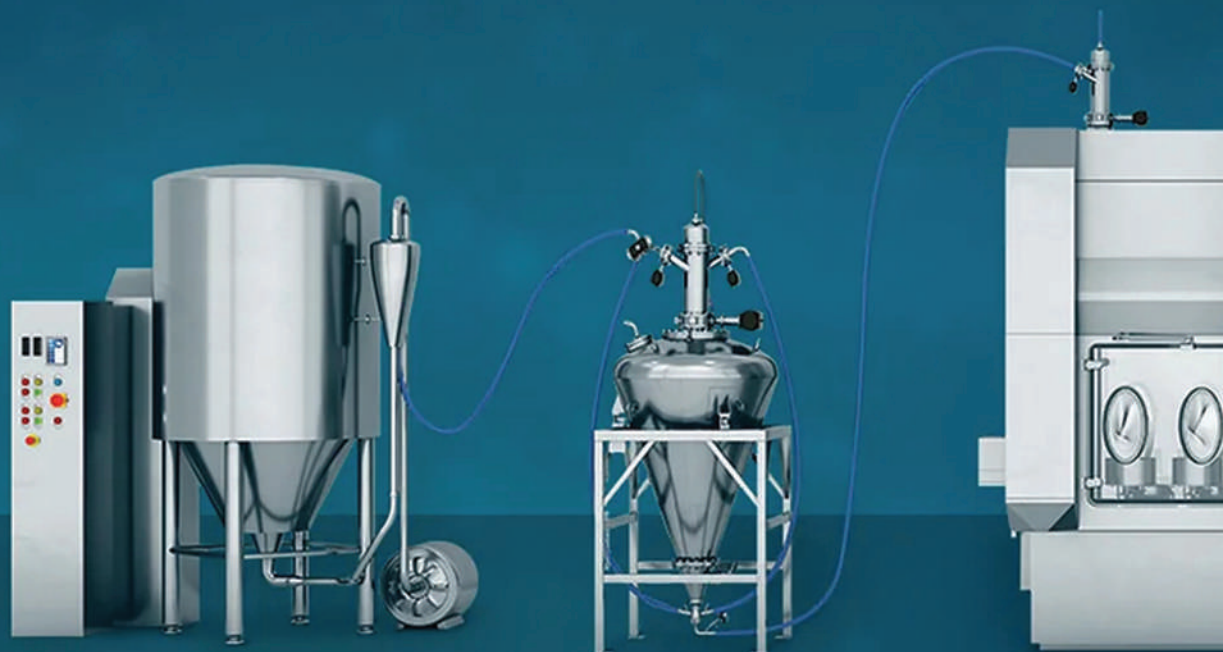

Granulation

Machinery / Process

ماشین آلات فرآیند

High Shear Mixing Granulator

- / Capacity of 1 liter to 2,000 liters.
- / Hygienic GMP design.
- / Mixing tool can be raised up for easy inspection.
- / User-friendly controls with predefined process steps.
- / Available as a single-pot mixing granulator.



Fluid Bed Processor

- / Single filter elements.
- / Easy to change parts.
- / Cleaning with compressed air shock.
- / Cleaning without any interruption to process.
- / Tissue or PTFE membrane.
- / Hygienic versions bring higher cleanability.
- / Suitable for: drying, granulation, coating, microencapsulation, and layering.

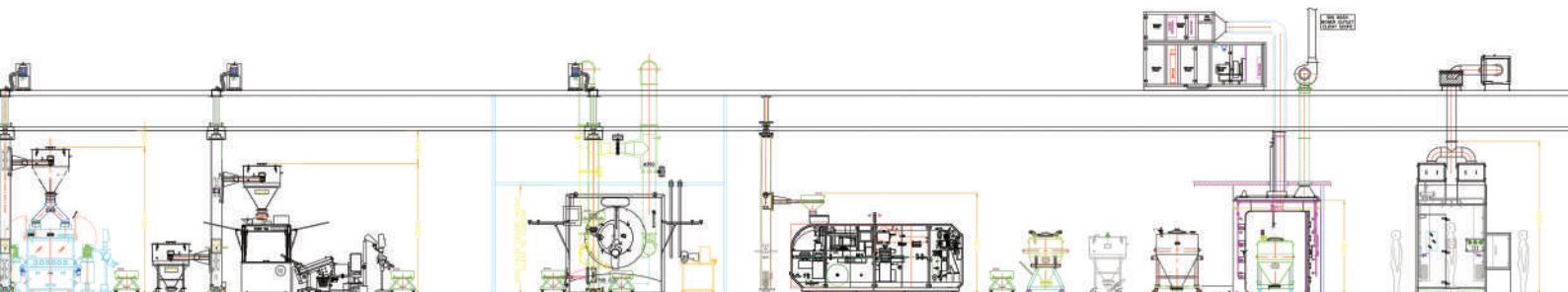

Coaters

- / Unique pan geometry.
- / 40% perforations.
- / Welded spiral baffles.
- / Air distribution management.
- / Spraying manifold.
- / 100% toolless discharge.
- / **Fastest** coating machine in the world.

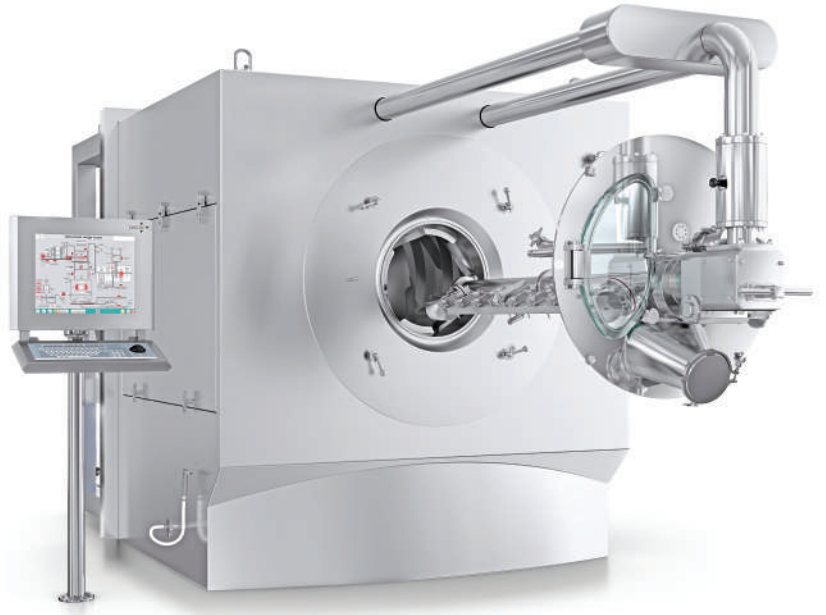

Bin Washing Machine

- / Efficient washing & drying cycle with minimum water use.
- / Washing time and water usage reduced by up to 30%.
- / Compliant with Title 21 CFR, Part 11.
- / Telescoping arrangement.
- / Washing of one to two bins at a time, depending on space availability.
- / Provision of cleaning accessories and change parts.

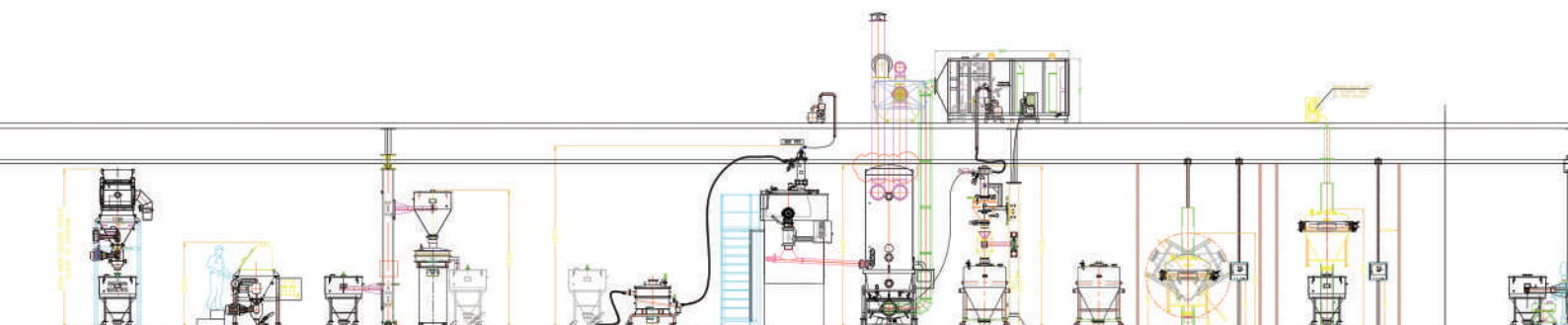
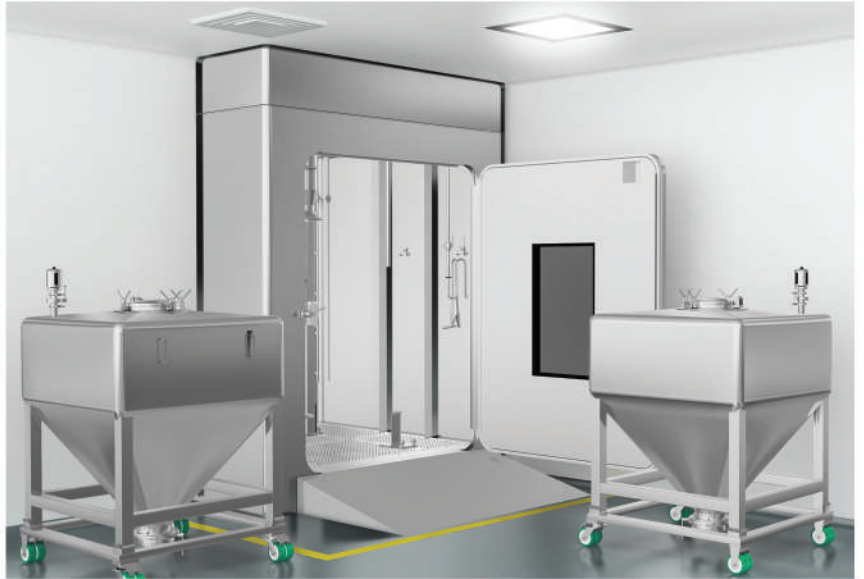

Production

Machinery

ماشین آلات تولید



Tablet Press Machine

- / Automatic weight control.
- / Metal detector and de-duster.
- / Compliant with Title 21 CFR, Part 11.
- / Design conforms to cGMP.
- / Measurement of main and pre compressors.
- / Bilayer and multilayer tablet press machines.
- / Tablet press from lab-scale to high speed double sided press.
- / All types of tools: B, D, BB, BBS, and exchangeable turret.

Other Production Machinery

- / Blow-filled Sealing (BFS)
- / Prefilled Syringe (PFS) Filling
- / Ampoule Filling Line
- / Liquid & Powder Filling Line



WASHING



FILLING



CAPPING

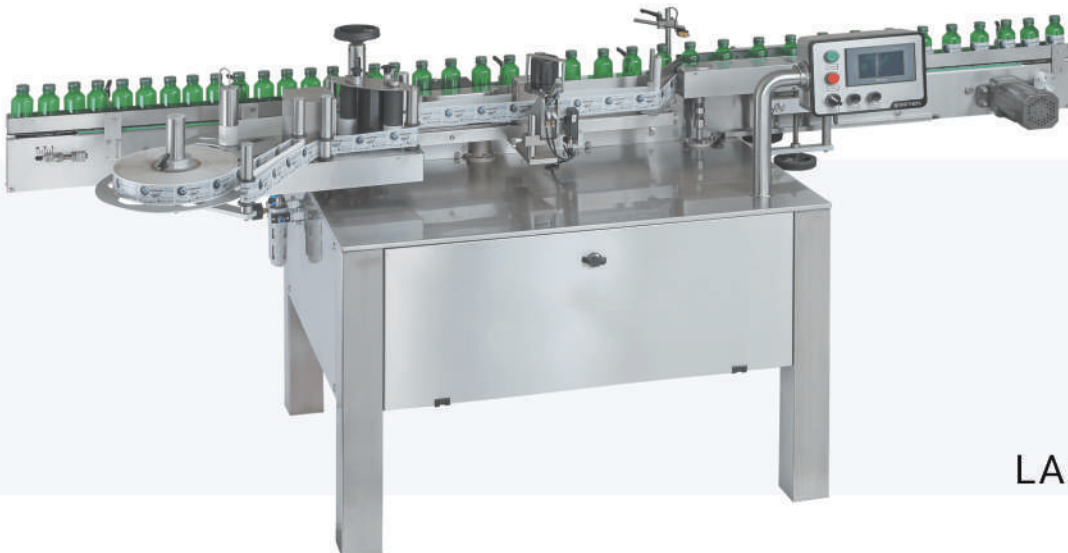

LABELING

Packaging Machinery

ماشین آلات بسته بندی

Blister Packing & Cartoning Machines

Providing comprehensive blister packaging solutions right from thermo-forming machine, cold-forming machines, and lab models.



- / Providing format parts for pharmaceutical blister packing and cartoning machines.
- / Easy plug and play of machines.
- / Vast experience in the supply of dedicated blister feeding solutions like brush feeder, dual feeder, and shuttle feeder.
- / Supporting 90+ models of blistering machines.

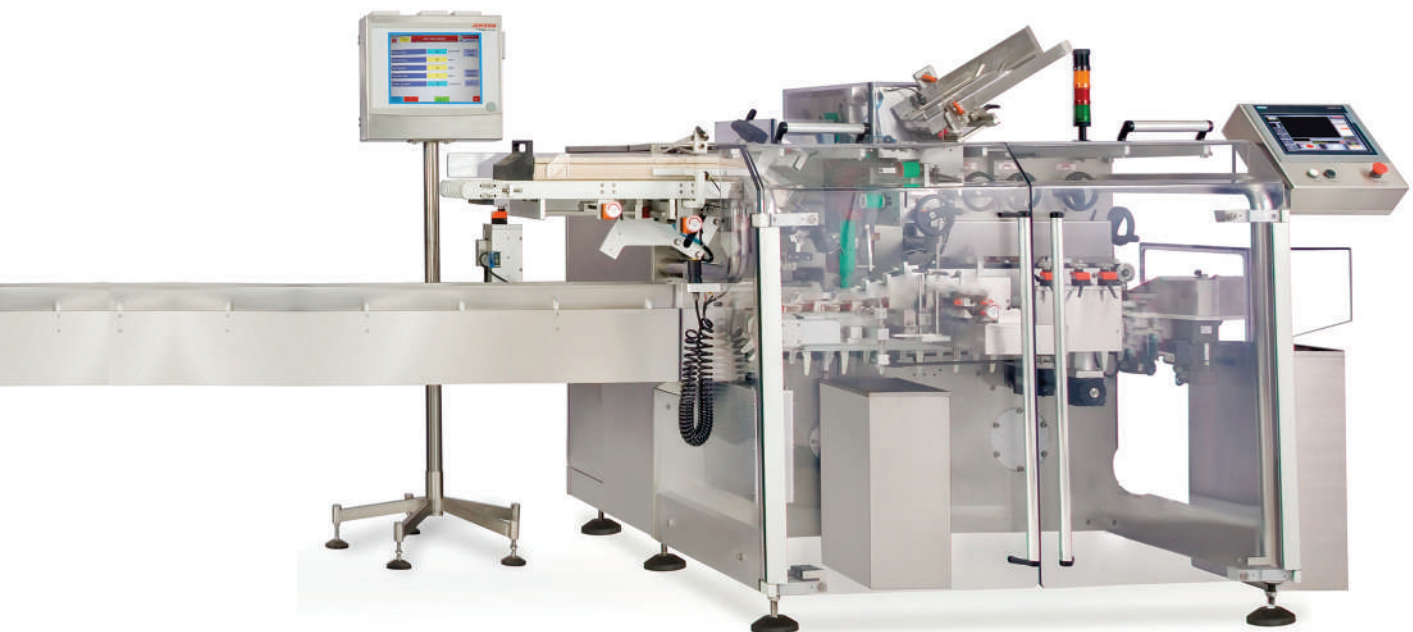

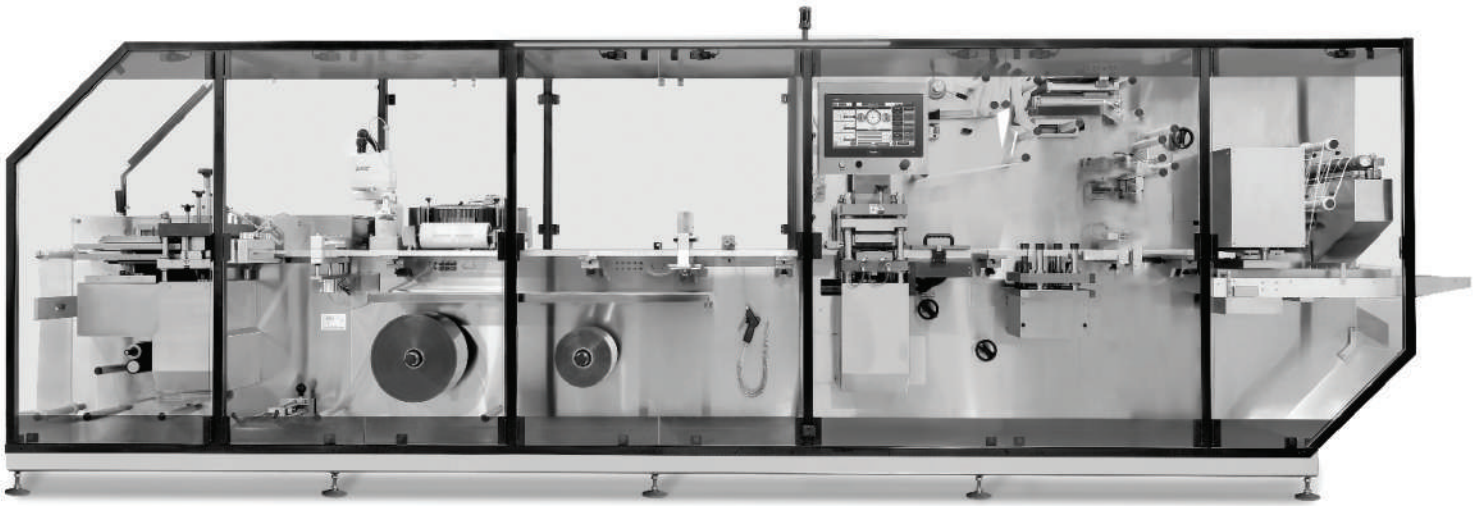

Suitable for:

- / Tablets
- / Bottles
- / Pre-filled Syringes (PFS)
- / Capsules
- / Ampoules



Advantages:

- / Remote serviceability.
- / Toolless changeover.
- / Operator-friendly design.
- / Very compact footprint.
- / Forming materials: Laminated Al Foils, PVC, PVDC, Duplex, Triplex, Aclar, PP.
- / Multiple robotic feeding stations.
- / Deep draw blisters for ampoules, vials, and syringes.

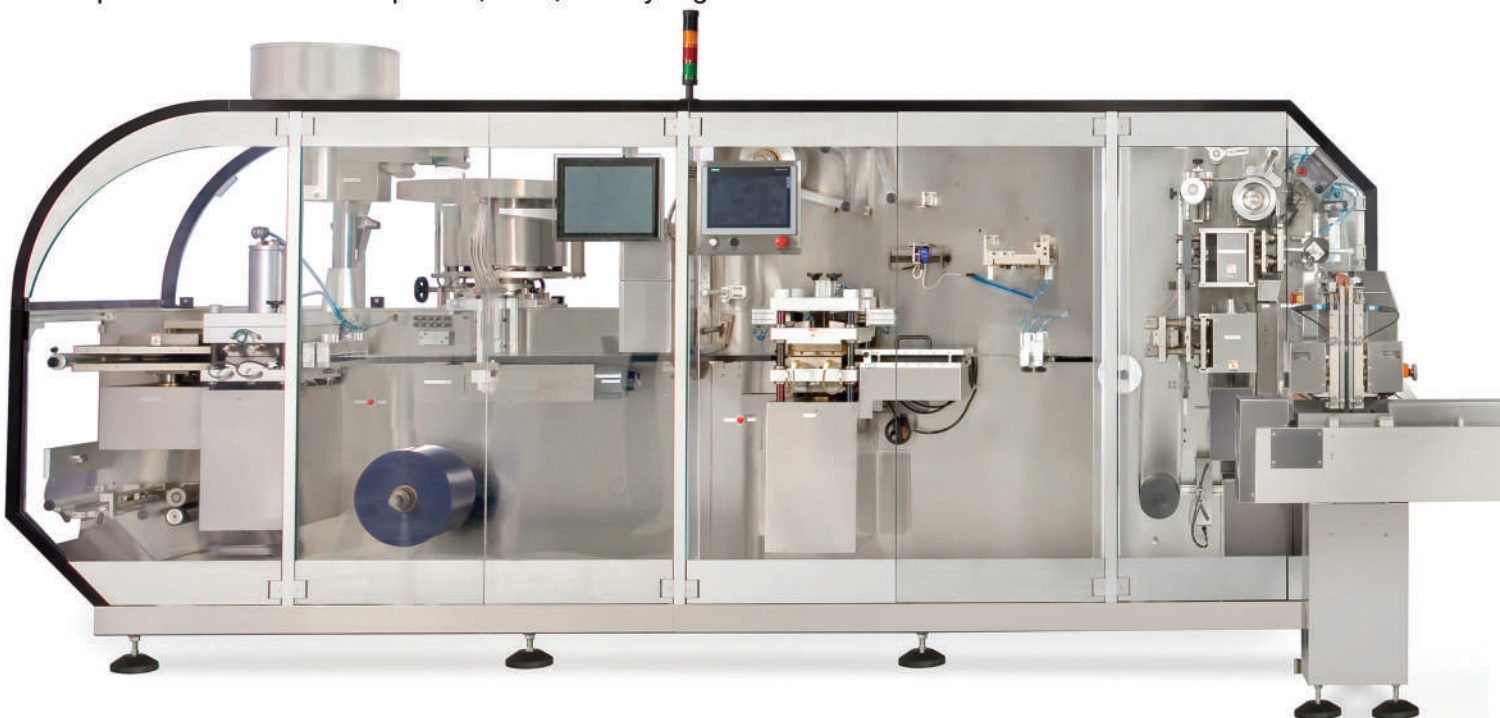

صنعت روغن، چربی و اولئوکمیکال

Oils, Fats, & Oleochemicals Industry

با بیش از بیست سال سابقه در تامین ماشین آلات تولیدی برای صنایع بالادستی و پایین دستی روغن خوراکی، شامل روغن کشتی با حلال، کنسانتره پروتئین، تصفیه انواع روغن خام، جز به جز سازی، اینتراستریفیکاسیون، هیدروژناسیون، مارگارین و شورتنینگ، بهبود چربی، الکل های چرب و غیره.

Within the department of Oils, Fats, & Oleochemicals, we facilitate the construction of seed oil extraction plants using the Engineering, Procurement, Construction, and Management (EPCM) project delivery approach. The upstream and downstream operations in manufacturing of edible oils comprise of technical processes like solvent extractions, refinery, fractionation, Interesterification, hydrogenation, fat modification that produce a high range of products such as edible oils, oleochemicals, margarines, shortenings, and seed-proteins. Throughout our 20 years history in this industry, we have constructed multiple factories that produce oilseeds and subsequent oilseed-derived materials, on turnkey basis, for our clients in Iran.



ماشین آلات و تکنولوژی روغن، چربی و اولئوکیمال Oils, Fats & Oleochemicals Equipment and Technology



E-Type Extractor



Cracker



Flaker



White Flakes



Conditioner



Meal Handling



Lecithin



Deodorizer



صنعت نشاسته و مشتقات

Starch & Derivatives Industry

با بیش از بیست سال سابقه در تامین ماشین‌آلات تولیدی برای صنایع بالادستی و پایین‌دستی نشاسته، شامل نشاسته خام، نشاسته اصلاح‌شده، گلوکز، دکستروز و فروکتوز، قندالکل سوربیتول، آمینواسید لیزین، اسیدآلی سیتریک اسید، بیواتانول و غیره.

Within the department of Starch & Derivatives, we facilitate the construction of grain processing plants using the Engineering, Procurement, Construction, and Management (EPCM) project delivery approach. The upstream and downstream operations in processing of grains result in a high range of products such as pure starch, modified starch, fructose, glucose, dextrose, sorbitol, lysine amino acid, citric acid, bioethanol...etc. Throughout our 20 years history in this industry, we have constructed multiple factories that produce high fructose corn syrups and other starch-derived materials, on turnkey basis, for our clients in Iran.



ماشین آلات و تکنولوژی نشاسته و مشتقات

Starch & Derivatives Equipment and Technology



Pin Mill



Centrifugal Separator

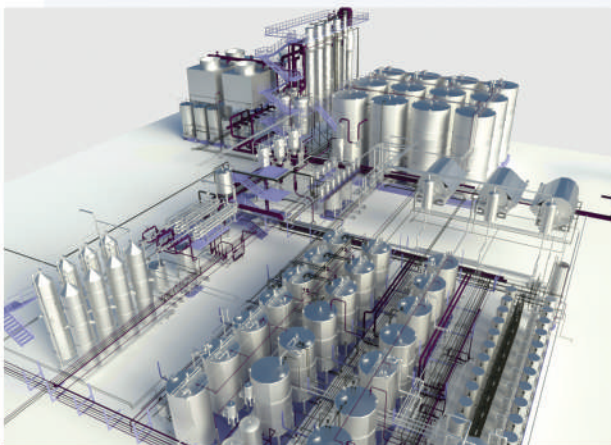

Starch-based Sweeteners



Ion Exchange System



Evaporator



Tube Bundle Dryer



Washing Cyclone

پروژه‌های اجرا شده

Our Reference Projects

Tehran Province:

- 360 MTPD Multiple Oil Refinery
- 200 MTPD Physical Oil Refinery
- 200 MTPD Hot Press

Golestan Province:

- 500 MTPD Soybean Crushing Plant
- 300 MTPD Corn Wet Milling
- 200 MTPD Winterization

Khorasan Razavi Province:

- 500 MTPD Soybean Crushing Plant
- 100 MTPD Degumming and Lecithin Drying

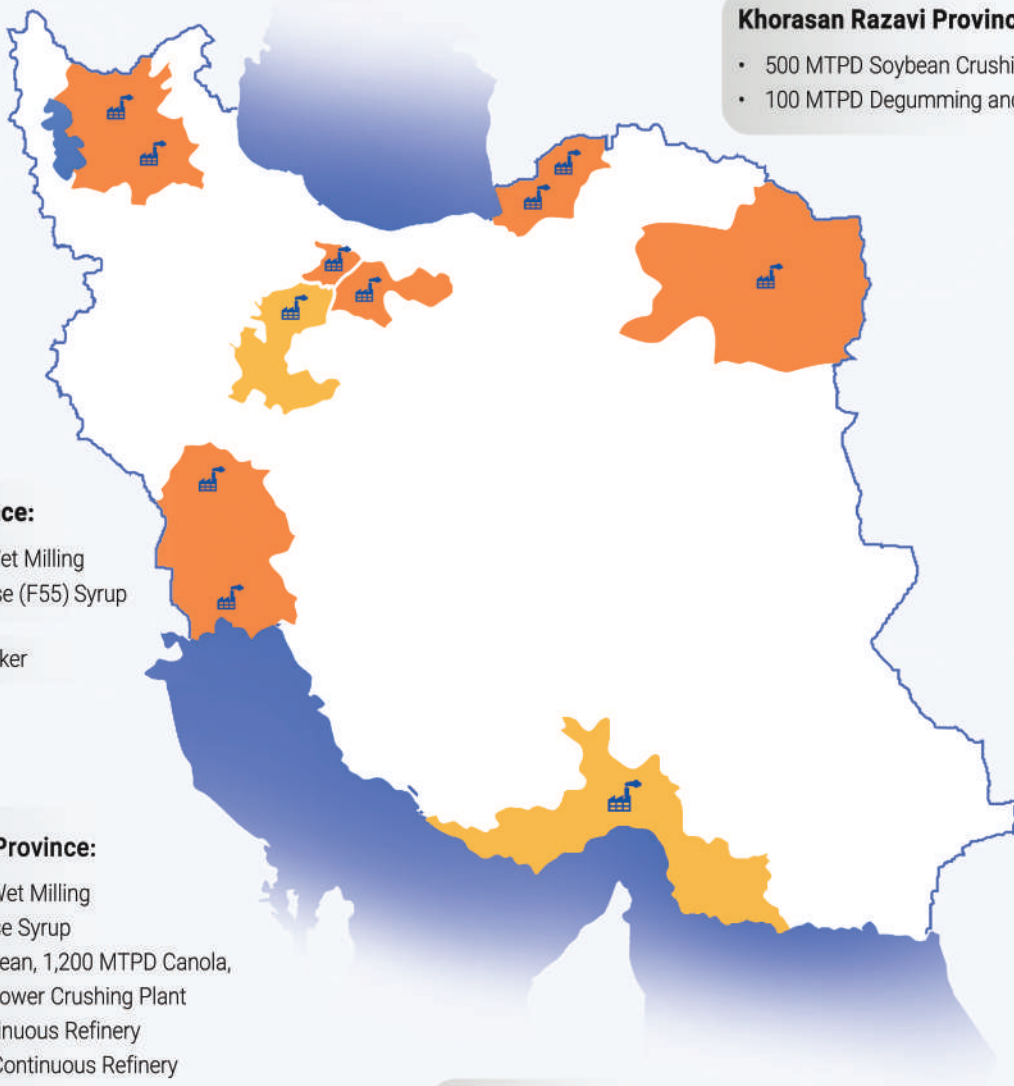

Khuzestan Province:

- 350 MTPD Corn Wet Milling
- 200 MTPD Fructose (F55) Syrup
- 2 x 500 MTPD Flaker

East Azerbaijan Province:

- 660 MTPD Corn Wet Milling
- 500 MTPD Glucose Syrup
- 1,500 MTPD Soybean, 1,200 MTPD Canola, 1,200 MTPD Sunflower Crushing Plant
- 1,000 MTPD Continuous Refinery
- 300 MTPD Semi-Continuous Refinery
- 500 MTPD Fractionation
- 160 MTPD High Pressure Fractionation
- 600 MTPD Neutralization
- 300 MTPD Winterization
- 100 MTPD Hydrogenation
- 200 MTPD White Flakes
- 15 MTPD Feed Grade Lecithin
- 10 MTPD Transparent Food Grade Lecithin
- 300 m³/h Hydrogen Generation

Alborz Province:

- 600 MTPD Corn Wet Milling
- 480 MTPD Fructose (F55) Syrup
- 150 MTPD Multiple Oil Refinery

Markazi Province:

- 150 MTPD Winterization and Bleaching Filters

Hormozgan Province:

- 150 MTPD Winterization Filter

- 120 MTPD Hydrogenation & Post Bleaching
- 120 MTPD Chemical Interesterification & Post Bleaching
- 150 MTPD Multi-Stock Deodorization

خطوط فرآوری غلات
Grains Processing Lines



ماشین آلات
و
انتقال تکنولوژی

مهندسی / تامین ماشین آلات / نظارت بر ساخت / نظارت بر نصب / نصب و راه اندازی / انتقال تکنولوژی.

Engineering / Procurement / Supervision of Construction / Supervision of Installation / Commissioning,
Technology Transfer



مدیریت پروژه

Project Management

مدیریت پروژه در گروه صباحی با رویکردی ساختارمند و مبتنی بر استانداردهای جهانی، از برنامه‌ریزی تا بهره‌برداری، مسیر تحقق اهداف پروژه را تضمین می‌کند. تمرکز ما بر مدیریت قراردادهای، زمان، هزینه، ریسک و منابع برای دستیابی به نتایج پایدار است.

At Sabahi Group, Project Management is delivered through a structured, internationally aligned approach, guiding projects from initial planning to final commissioning. We focus on the strategic management of contracts, schedules, costs, risks, and resources, ensuring that each project is executed efficiently and achieves sustainable, high-quality results. By maintaining full visibility and proactive oversight, we turn complex industrial projects into successful, reliable outcomes that meet the expectations of clients and stakeholders.

Project Coordination

هماهنگی کامل همه‌ی تیم و فعالیت‌ها در
راستای پیشرفت پروژه



We Coordinate

Clear Communication / ارتباط شفاف

Shipment Follow-Up / پیگیری حمل

Site Readiness / پیگیری آماده‌سازی سایت

Installation Coordination / هماهنگی نصب

Commissioning Support / پشتیبانی راه‌اندازی



We Ensure

Progress Tracking / پیگیری پیشرفت پروژه

Stakeholder Alignment / هم‌راستایی ذی‌نفعان

Early Risk Detection / تشخیص سریع ریسک

Delivered in collaboration with
international technology partners.

با همکاری شرکای فناوری بین‌المللی.

PAYMENT TRACKING

Invoice No.	Date	Vendor	Description	Contract Value (\$)
INV-2401-001	005	Vendor A	Engineering	1,250,000
INV-2401-002	005	Vendor B	Equipment Supply	1,500,000
INV-2401-003	005	Vendor B	Steel Structure	1,200,000
INV-2401-004	006	Vendor D	Mechanical	1,100,000
INV-2401-005	006	Vendor D	Instrumentation	1,200,000
INV-2401-006	006	Vendor E	Piping	1,500,000
INV-2401-007	004	Pompe F	Electrical	1,800,000
INV-2401-008	005	Vendor F	Fluidicals	1,200,000
INV-2401-009	005	Vendor F	Excavators	5,000,000
INV-2401-010	005	Vendor E	Civil Works	1,200,000
INV-2401-011	005	Vendor G	Commissioning	1,200,000

SEP OCT NOV DEC



PROJECT PROGRESS REPORT

SUMMARY	
Overall Progress	68%
Schedule Performance	-6%
Cost Performance	+4%

- KEY MILESTONES
- Piping fabrication is ahead of schedule by 8%.
 - Equipment deliveries on track.
 - Site construction progress is slightly behind due to weather.
 - No major safety incidents.

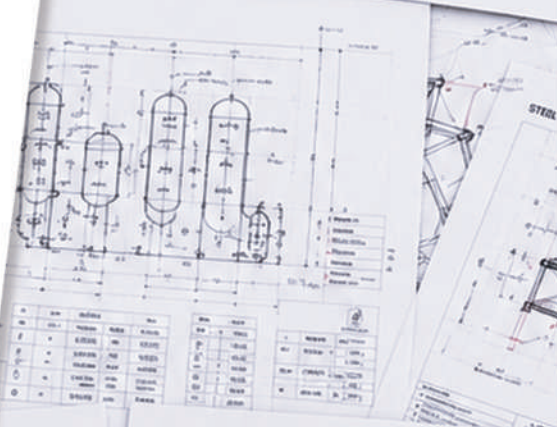

MATERIAL TRACKING

MATERIAL	Specification	UNIT	ORDERED	RECEIVED	BALANCE
Piping	A106 Gr B	M	100	100	100
Flanges	A105	EA	100	100	100
Fittings	A234 WPB	EA	100	100	100
Valves	API 600	EA	100	100	100
Bolts & Nuts	ASTM A193 B7	EA	100	100	100
Gaskets	Spiral Wound	EA	100	100	100
Plates	SAS16 Gr 70	EA	100	100	100
Tubes	A312 TP316L	SET	100	100	100

TRACKING

Description	Vendor	PO Date	Delivery Date	Status
Heat Exchanger	Vendor A	10/02/24	20/05/24	In Progress
Reactor Vessel	Vendor B	15/02/24	25/05/24	In Progress
Pumps	Vendor C	20/02/24	10/06/24	In Progress
Structures	Vendor D	05/03/24	15/06/24	In Progress
Instrumentation	Vendor E	12/03/24	30/06/24	In Progress
Electrical MCC	Vendor F	18/03/24	05/07/24	In Progress
Steel Structure	Vendor G	22/03/24	15/07/24	In Progress

RISK REGISTER

ID	Risk Description	Category
R-01	Delay in Equipment Delivery	Schedule
R-02	Weather Delay	External
R-03	Design Change	Technical
R-04	Vendor Performance	External
R-05	Site Safety Incident	HSE

BILL OF MATERIAL

Item	Description	Material	Qty
C-100	Column 100	MER200 A36	215
E-100	Beam 100	AP240	A36
B-100	Bracing 100		

Full Project Visibility

کنترل کامل جزئیات پروژه،
از برنامه‌ریزی تا اجرا در یک نگاه



نمای کلی پیشرفت پروژه



- تکمیل شده %۷۲
- در حال انجام %۲۰
- برنامه‌ریزی شده %۸

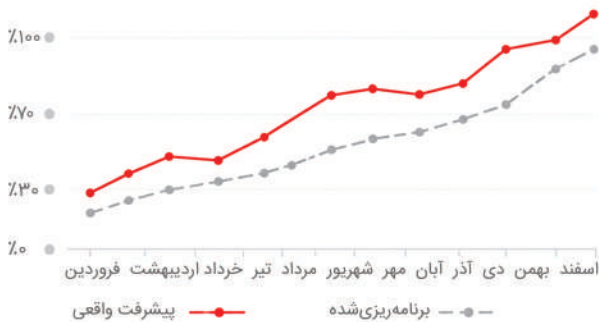

- ⚠ ۷ مسئله باز
- 🛡 ۹ ریسک فعال



شفافیت کامل، کنترل بی‌وقفه، پیشرفت مطمئن



EPC Projects

از ایده تا تحویل نهایی، کیفیت، زمان و هزینه تحت مدیریت و کنترل ما

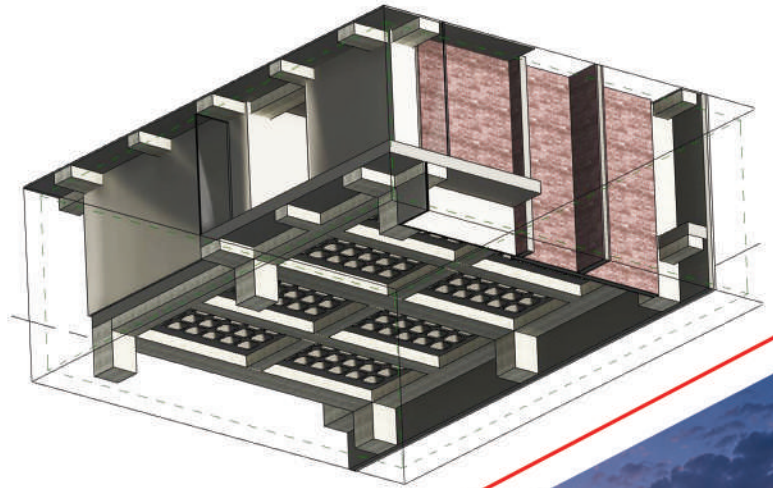

Project Delivery

Planning / برنامه‌ریزی

Procurement / تأمین

Construction / ساخت و ساز

Installation / نصب

Commissioning / راه‌اندازی



Project Control

Schedule Control / کنترل زمان‌بندی

Budget Control / کنترل بودجه

Risk Management / مدیریت ریسک

Performance Monitoring / نظارت بر عملکرد

**End-To-End
Execution Capability**

اجرای یکپارچه،
تحویل بدون نقص



صنعت تایر و لاستیک

Tire & Rubber Industry

با بیش از چهار دهه سابقه در حوزه واردات، تامین و توزیع مواد اولیه صنعت تایرسازی و لاستیک کشور، توانسته است به یکی از شناخته شده ترین نامها در میان تامین کنندگان مواد شیمیایی تبدیل شود.

The Tire & Rubber department of Sabahi Enterprises Co. facilitates the provision of essential resources such as raw chemical materials, machinery, spare parts, and technology to tire and rubber manufacturers of Iran. With a presence spanning over four decades, Sabahi has established a strong reputation and gained significant recognition as a reputable supplier in this sector in the country.



انواع مواد اولیه و ماشین‌آلات تولید تایر و لاستیک به صورت ارزی و ریالی برای تولیدکنندگان این صنعت در کشور تامین می‌گردد.

A broad range of materials for the manufacturing of tires & rubbers, ranging from raw chemicals to machinery and spare parts are available to our customers, Iranian producers in this industry, both locally and through overseas sales.

مشتریان ثابت ما Our Customers

این واحد، به عنوان نماینده انحصاری تامین‌کنندگان معتبر خارجی در حوزه تامین مواد اولیه، ماشین‌آلات، قطعات یدکی و انتقال تکنولوژی توانسته است در ارتقا سطح کیفیت تولیدات و دانش فنی تولیدکنندگان داخلی نقش بسزایی داشته باشد. به سبب کیفیت بالا در خدمت‌رسانی و سابقه درخشان در تامین مواد اولیه، این مجموعه همواره انتخاب اول تولیدکنندگان بزرگ در صنعت تایر و لاستیک می‌باشد.

Sabahi has been able to effectively support Iranian manufacturers of tires & rubbers through the establishment of exclusive partnerships with globally recognized suppliers of raw materials for this sector. As a result of our extensive four-decade history in this particular field, we have developed an expert's awareness of the requirements that the market and our customers have, and we do everything in our power to meet those requirements. It is a part of our commitment to our customers to maintain an up-to-date knowledge of all the latest developments in tire and rubber manufacturing technology worldwide, and to be promptly available to assist them with their research and development endeavors. Our goal is to continue to be a source of support and reliability for our clients while also playing an important part in our nation's advancement in this field.



انواع مواد اولیه شیمیایی Chemical raw materials

/ شتاب دهنده‌ها
/ آنتی اکسیدانت‌ها
/ عوامل پخت
/ کمک فرآیندها

/ Accelerators
/ Antioxidants
/ Curing Agents
/ Processing Aids



لاستیک‌های طبیعی و سنتزی Natural and synthetic rubbers

/ ورق‌های دودی آجدار (RSS1, RSS3)
/ لاستیک‌های استاندارد مالزی ۱۰ و ۲۰
/ لاستیک‌های استاندارد تایلند ۱۰ و ۲۰
/ لاستیک‌های سنتزی استایرن بوتادی ان

/ Ribbed Smoked Sheets RSS1 and RSS3
/ Standard Malaysian Rubbers 10 & 20
/ Standard Thai Rubbers 10 & 20
/ Synthetic Styrene Butadiene Rubbers



استیل کورد و نخ تایر Various types of cords and fabrics

/ نوار تسمه نقاله
/ نایلون
/ نخ تایر پلی استر
/ سیم‌های استیل تایر

/ Conveyor Belts and Fabrics
/ Nylon Tire Cords
/ Polyester Tire Cords
/ Steel Cords

قطعات و ماشین‌آلات صنعت تایر و لاستیک

Machinery and spare parts specific to the tire & rubber industry

/ واشرها و اورینگ‌های لاستیکی
/ اکستنشن سوپاپ تایر
/ ولوها
/ زنجیره کامل ماشین‌آلات تایر و
لاستیک و انتقال تکنولوژی

/ Rubber Seals and O-rings
/ Valve Extensions for Tires
/ Valves
/ Whole chain of tire & rubber
manufacturing machines





صنعت پلیمر و پلاستیک

Polymers & Plastics Industry

مشاوره، تأمین، نصب و راه‌اندازی خطوط کامل تولید آمیزه‌های پلیمری.
دارای نمایندگی انحصاری شرکت Jiangu Xinda Tech Limited در ایران.

In the Polymers & Plastics division of Sabahi Enterprises Co., we are the exclusive representative of Jiangu Xinda Tech Limited, through which we offer the full range of machinery as well as installation and commissioning services to customers who desire to manufacture polymer-based compounds.



ماشین آلات و تکنولوژی صنعت پلیمر

Equipment and Technology for the Polymer Industry



Co-kneader



Ancillary Equipment



Lab Use Extruder



Twin Screw Extruder



Spare Part Service



پودرهای میکرونیزه ایران Micronized Powders of IRAN

شرکت پودرهای میکرونیزه ایران به عنوان یکی از پیشگامان تامین نیاز صنعت پلیمر کشور در سال ۱۳۶۴ به عنوان واحد صنعتی-تولیدی تأسیس گردید. این واحد تولیدی دارای پروانه فعالیت واحد تحقیق و توسعه و گواهینامه استاندارد (ISO 9001: 2015) می باشد.

Micronized Powders Co. is the industrial-manufacturing subsidiary of Sabahi Group. MPC is recognized as the pioneer manufacturer of its products in Iran and is respected as a dependable source of these materials by its clients globally. MPC's products are particularly used by tire, rubber, paint, wire, and cable manufacturers, and are suitable for use in the production of various other polymer-based products.

SINCE 1985

از سال ۱۳۶۴

پیگمنت سیاه
Black Pigment

هیدروکسید آلومینیوم
Aluminium Hydroxide

کامپاند
Coumpand

مستر بچ سیاه
Black Masterbatch



9001:2015



45001:2018

Vision

پیشگامی در صنعت، با تولید بهترین محصولات و عرضه آنها به مشتریان با بهره‌گیری از خطوط به‌روز دنیا و همچنین حفظ جایگاه شرکت به عنوان گروهی مشتری‌مدار، در تولید مواد اولیه برای صنایع مختلف کشور.

To be the topmost reliable supplier in the industry by manufacturing materials of the highest possible quality utilizing cutting-edge production lines, and to keep up our strong reputation in the market as a company that is focused on serving the needs of our clients in a variety of industries and our country.

MISSION

به صورت دائم، در حال سرمایه‌گذاری جهت رفع نیازهای مشتریان برای محصولات و تکنولوژی جدید هستیم. تولید و ارائه بهترین محصولات با کمترین قیمت، بالاترین کیفیت، توأم با ارسال سریع سفارشات در مسیر حرکت شرکت پودرهای میکرونیزه ایران می‌باشد.

To remain abreast of the most recent industry developments and trends in order to provide our clients with innovative products and services. Micronized Powders Company is committed to providing superior products with optimal quality and competitive pricing, along with efficient order fulfillment processes to ensure prompt delivery and customer satisfaction.

VALUES

اعتماد به نیروی انسانی / متعهد در ارائه اطلاعات، ارسال نمونه و تحویل محصول نهایی یکسان / اعتقاد به روحیه کار تیمی

Complete transparency in all aspects of our operations / Creating and delivering high-quality products / Providing our clients with excellent customer service / Strong belief in the power of teamwork.

PRINTON[®]

We Don't Just Make Black, We Own Its Journey.

- Printon is a black pigment with proven performance, engineered from high-quality carbon black, delivers deep color. Offered in four functional series: HC, MC, RC and Separation to meet diverse industrial demands from striking visual effects to technical performance. Provide excellent tinting strength, reinforcement, UV protection for demanding applications.



	Masterbatch and Compound	PVC industry	Wire and Cable Sheath	Synthetic Leather & Textile	Industrial & Automotive coating	Architectural coating	Inks	Powder Coating	Pigment Paste	Tire & Industrial Rubber	Adhesives	Refractories products
Printon HC Alpha					⊕							
Printon HC Pro	○	○			⊕	⊕	○					
Printon HC Eco	⊕		○									
Printon MC Alpha								⊕				
Printon MC Pro			⊕				⊕					
Printon MC Eco	○	○	○			○	⊕					
Printon RC Alpha	○	○	○	⊕	⊕	⊕	⊕				⊕	
Printon RC Pro	⊕	⊕	⊕	⊕	○	⊕		⊕	⊕	○		⊕
Printon RC Eco	○	○	○			○						○
Printon Separation Alpha										⊕	○	
Printon Separation Pro							⊕			⊕		
Printon Separation Eco							○			○		
Printon Dust-Free												

⊕ Especially recommended

○ Well suitable



PRINTONMASTER®

Mastery in Every Pellet

- PrintonMaster is a premium black masterbatch made with a PE carrier with 25-60% carbon black content and Printon pigment for deep color, UV protection and lasting durability. Available in three series: Extrusion, injection and Film for consistent, high-quality results.

Base Polymer	Name				Spec	Application											
	CB %	Carbon Type	Filler %	Filler Type	Ash %	Film	Pipe	Cable	Geomembrane	Injection	Compound	Blow Molding	Irrigation Tape				
HDPE	60 %	ISAF	Noun	<0.1						⊕							
		FEF						⊕									
	50 %	FEF							⊕								
		ISAF											⊕				
	40 %	P-Type											⊕			⊕	
		FEF															
	20 %	FEF															
		HAF				60 CC%								⊕			
		SRF				60 CC%											
						55 CC%											
LDPE	50 %	HAF	Noun	<0.1		⊕					⊕		⊕				
		FEF				⊕				⊕		⊕					
	40 %	HAF				⊕				⊕		⊕					
		FEF				⊕				⊕		⊕					
LLDPE	50 %	FEF	Noun	<0.1		⊕				⊕		⊕					
	40 %	HAF				⊕				⊕		⊕					
	30 %	HAF				⊕				⊕		⊕					
PVC	40 %	HAF	Noun	<0.1													
	30 %					⊕											



PRINTONMIX[®]

Where Flow Meets Strength.

- PRINTONMIX is an advanced PE based Black Compound, optimized for superior dispersion, UV resistance and thermal stability. Reliable, durable and versatile for long-lasting performance in demanding applications.

USAGE	Name		Spec	Application							
	Carbon Type	Ash %	Film	Pipe	Cable	Geomembrane	Injection	Compound	Blow Molding	Irrigation Tape	
HDPE	FEF	Noun		⊕							
	P-Type			⊕						⊕	
LDPE	FEF	<0.1	⊕					⊕	⊕		
	P-Type		⊕					⊕	⊕		
LLDPE	N-330		⊕				⊕	⊕	⊕		
	N-550		⊕					⊕	⊕		
PVC	N-330					⊕					
						⊕					

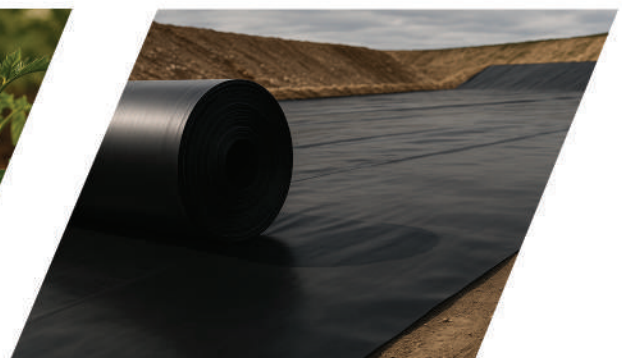
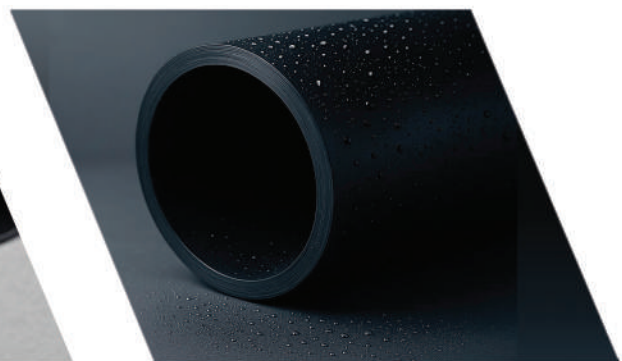
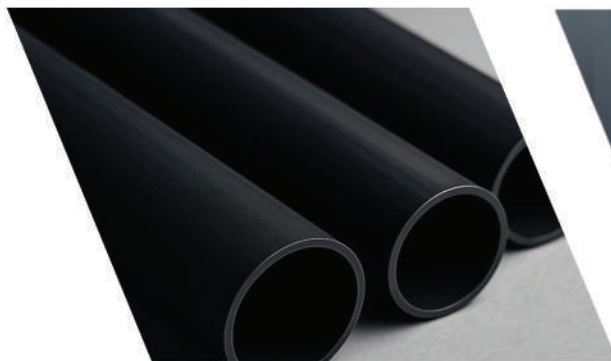

ALUXIDE®

Purity in Every Particle

- Aluxide is a high-purity aluminum hydroxide powder available in two series: Regular (1-75 microns) and Seface modified (SM). Widely used for flame retardancy, catalyst processes, solid surfaces and heat-resistance composites



Particle Size	ATH Type	Whitness	Wire & Cable Sheath	Catalyst	Corian Stone	Silicone insulator	Composite sheets	Coating	Construction industry	Heat-resistant fillers
1	P	94%	⊕		○		⊕	⊕	⊕	⊕
1	M	94%	○		○		○	○	○	○
1	M	90%		⊕	○	⊕	⊕	⊕	⊕	⊕
5	M	94%		○	○	○	○	○	○	○
5	M	90%			⊕		⊕		⊕	
25	M	94%			○		○		○	
25	M	90%			○		○		○	
50	M	94%			○		○		○	
50	M	90%			○		○		○	
75	M	94%			⊕					
75	M	90%			○					
SM	P	94%	⊕							
SM	M	90%	○							

⊕ Especially recommended

○ Well suitable

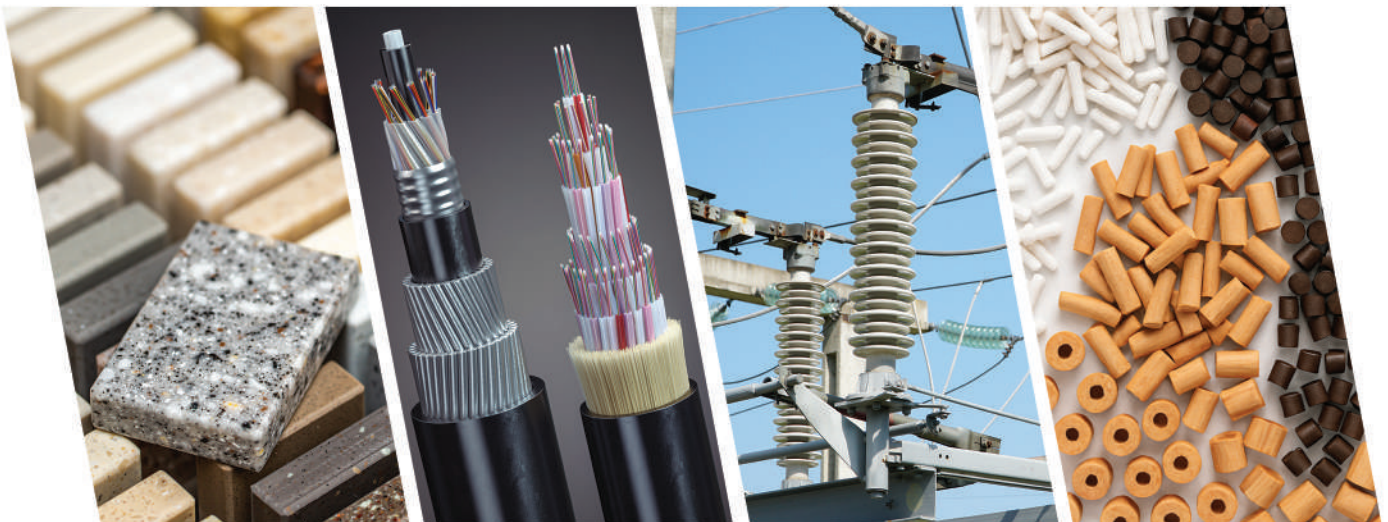

CABSHIELD®

Engineered for Safety. Built to Last



- Cabshield is a halogen-free flame-retardant compound (HFFR) designed specifically for cable insulation, helping reduce heat, smoke, and toxic emissions during fires, ensures strong mechanical performance and easy processing, ideal for modern residential and industrial cable applications.

LOI	Ellangation	Grade	Advantages
Power	Insulation	Alpha	LOI >35, Meet the Single Vertical Combustion for Thermoplastic Building Wire (IEC60332-1)
		Eco	Standard Flame and crack resistant, low smoke, safe and easy to process
	Sheath	Alpha	Meet the Requirement on Bundle Combustion A and B Category (IEC60332-3A/B)
		Pro	Meet the Requirement on Bundle Combustion A and B Category (IE060332-3C)
		Eco	Self-extinguishing, low-toxicity, strong and extrudes easily
Communication	Insulation & Sheath	Alpha	High-speed extrusion, Meet IEC 60332-1 Standard
		Pro	High-speed extrusion
Transportation	Insulation & Sheath	Alpha	Meet the standard QC/T1037
		Pro	Meet the standard QC/T1037
Energy	Insulation & Sheath	Alpha	High-speed extrusion, Meet EN50618 standard and the light transmittance reaches more than 60%
		Pro	High-Speed Extrusion
Construction	Insulation & Sheath	Alpha	LOI≥38; Bundle combustion ABC for 1.5mm ²
		Pro	LOI≥35; Bundle combustion AB for 1.5mm ²
Electronics	Insulation	Alpha	Elongation at break is over 300%
	Insulation & Sheath	Pro	Good bending resistance

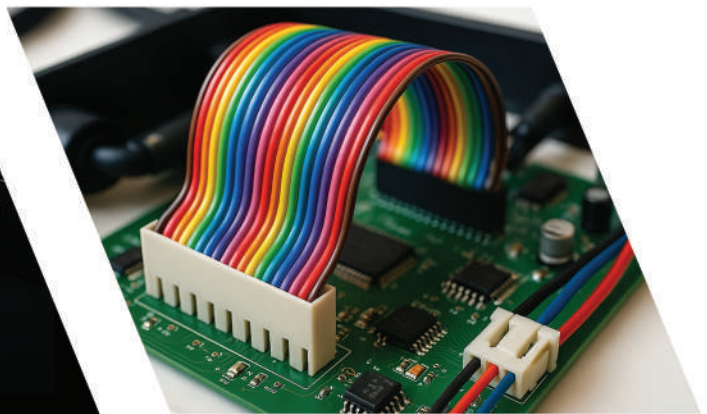

PEXLANE[®]

The Pulse of Power

PEXIDE[®]

From MV to HV—PEXIDE Powers Critical Connections

Pexlane and pexide are cross-linked PE compounds (XLPE) for every voltage range, Providing electrical reliability, thermal resistance and mechanical strength for consistent performance in cable applications.

PEXIDE	Series	Distinction	Grade	Advantages
	HV	252kV	Alpha	Super clean, the material meets the cable standard IEC62067 after extrusion processing
		170kV	Alpha	Super clean, the material meets the cable standard IEC60840 after extrusion processing
		72.5kV	Pro	Super clean, the material meets the cable standard IEC601831 after extrusion processing
		66kV	Pro	The performance of the water-tree retardant material conforms to enterprise standard Q/ZWGC 001-2024, with high cleanliness
	MV	35kV	Alpha	≤10 impurities/1000g for >100μm
		35kV	Pro	Standard peroxide XLPE
		10kV	Alpha	No impurities > 130 μm per 1000 g
		10kV	Pro	Standard peroxide XLPE

PEXLANE	Series	Grade	Advantages
	Power	Alpha	Best for fast curing & harsh environments
		Pro	Standard, simple processing
	Communication	Alpha	Solder shrinkage resistance and good shaping
	Transportation	Alpha	Thin-wall wire with insulation thickness of 0.2mm; no crack at brittleness temperature -76 C
	Industrial equipment	Alpha	Excellent aging resistance and Shore A hardness of about 88
	Energy	Alpha	Can meet 1500h*240h aging



A B O U T I R A N



Tehran / Ski Resort



Mesr Desert



Chabahar



Facts about Iran:

2nd largest economy in the Middle East.

2nd largest proved gas reserve, spanning 33.6 trillion cubic meters.

3rd largest natural gas producer.

4th rank in world oil reserves.

10th rank in world iron reserves.

16th rank in world copper reserves.

17th most populous country in the world with a population of 91.5 million living across a total 1,630,848 sq. km area.





S A B A H I
BUILDING / SPRING



SABAHİ
BİLDİNG / WİTER



Tel.: +98 21 88 74 06 80-9

Fax : +98 21 88 74 42 84



پودرهای میکرونیزه ایران
Micronized Powders of IRAN

Tel.: +98 21 88 74 39 30-4

Fax : +98 21 88 74 42 84

تهران، خیابان خرمشهر، شماره ۱۴۲، ساختمان صباحی

Sabahi Building, 142 Khorramshahr St, Tehran, Iran

www.sabahi.com

info@sabahi.com

V3/062026